

EFORT

ESR50-4-1200

ESR50-4-1200,
Maxium payload 50 kg with maxium reach 1200 mm.

- **Highlights**
 1. High rhythm and high precision
The fastest standard cycle time can reach 0.81 s, and the robot positioning accuracy can reach 0.05 mm.
 2. High rigidity and low vibration
Robot body mode and rigidity enhancement, combined with vibration suppression and active vibration suppression functions, effectively reduce vibration.
 3. Easy to maintain and scalable
The detachable structure of cables and batteries allows for the replacement of robots inside the device.
- **Applications**
It can be used in handling, sorting, assembly, etc.
- **Industries**
Suitable for industries such as 3C electronics, lithium batteries, automotive electronics, and photovoltaics.



SPECIFICATIONS

Model		ESR50-4-1200
Reach		1200 mm
Max. payload on wrist	Rated	20 kg
	Maximum	50 kg
Robot weight		142.5 kg
Maximum speed	J1+J2	8400 mm/sec
	J3	1000 mm/sec
	J4	564°/sec
Motion range	J1	±130°
	J2	±150°
	J3	400 mm
	J4	±180°
Repeatability	J1+J2	±0.05 mm
	J3	±0.02 mm
	J4	±0.01°
Standard cycle time		0.81 s
J4 allowable moment of inertia	Rated	0.5 kg·m ²
	Maximum	2.5 kg·m ²
Electric lines		D-Sub 15-Pin
Pneumatic lines		φ6 mmx3
J3 downward force		1000 N
Installation		Floor
Installation enviroment	Ambient temperature	5~40°C
	Ambient humidity	RH≤80% (No dew nor frost allowed)

OPERATING SPACE

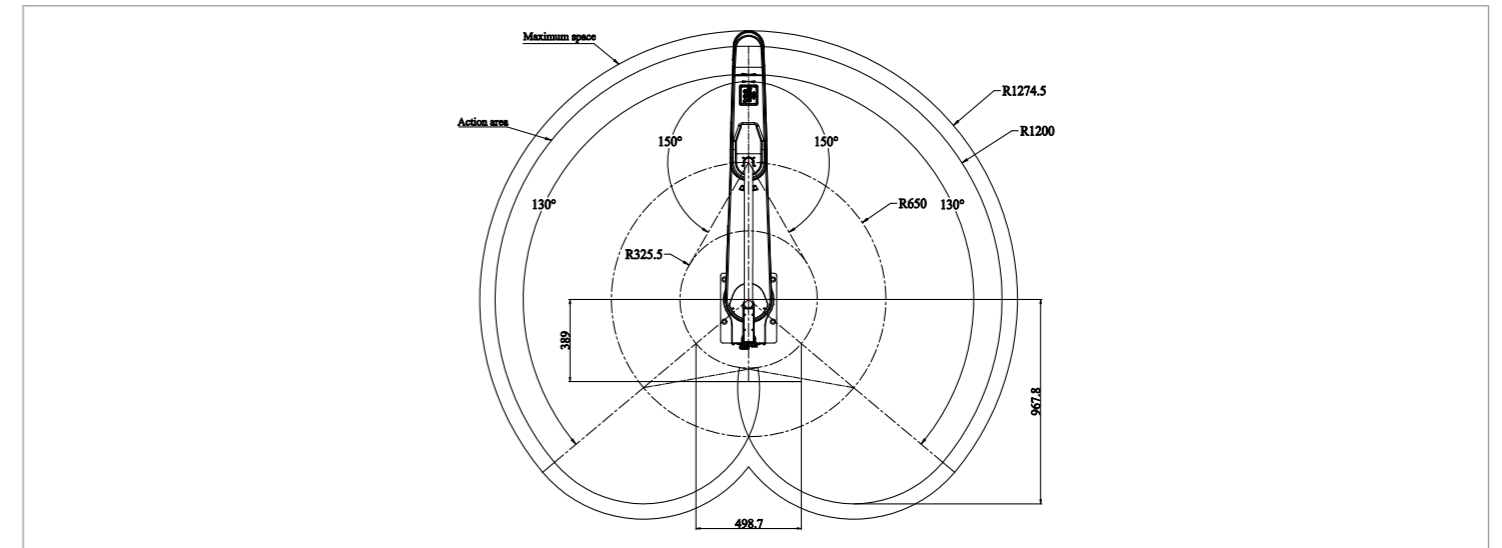

BASE MOUNTING SIZE

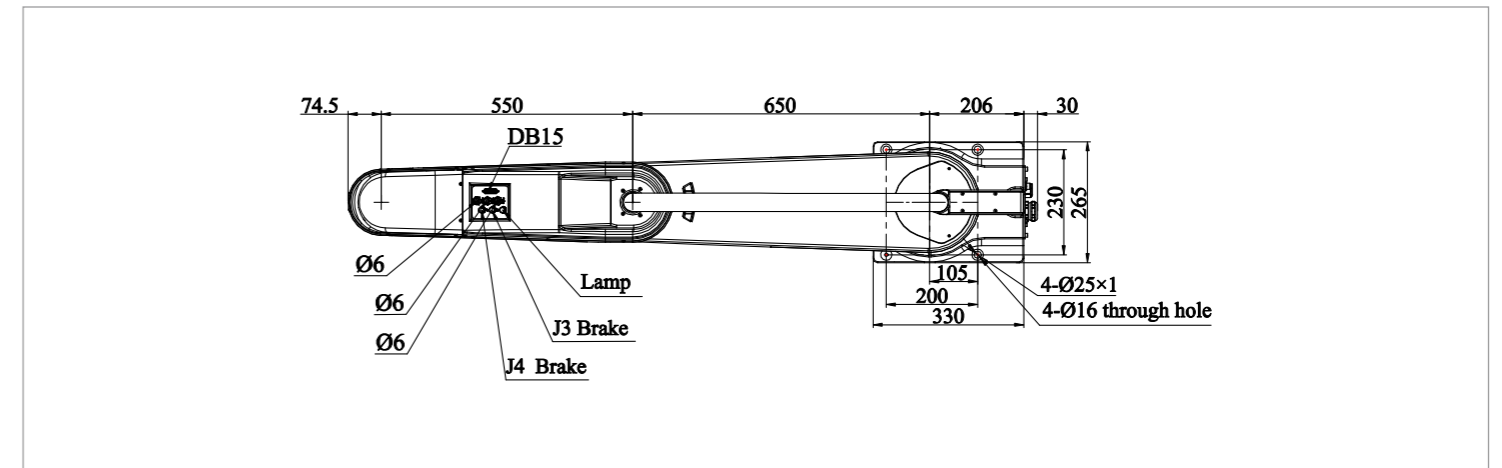

END FLANGE MOUNTING SIZE

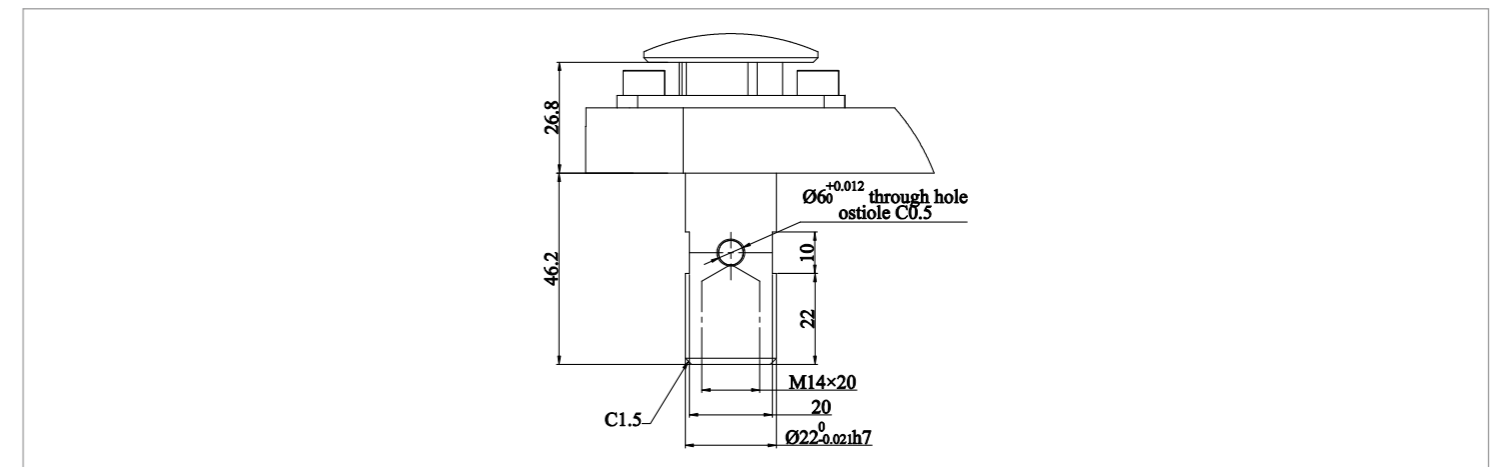

Information Release Time 2024/01

PHONE: (00 86) 400-052-8877
 ADDRESS: No.96 East Wanchun Road, China(Anhui) Pilot
 Free Trade Zone Wuhu Area, Wuhu, Anhui Province, China
 WWW.EFORT.COM.CN

EFORT INTELLIGENT EQUIPMENT CO.,LTD.