

EFORT

ESR10-800Z42

ESR10-800Z42,
Maxium payload 10 kg with maxium reach 800 mm.

- **Highlights**
 1. High rhythm and high precision
The fastest standard cycle time can reach 0.475 s, and the robot positioning accuracy can reach 0.025 mm.
 2. High rigidity and low vibration
Robot body mode and rigidity enhancement, combined with vibration suppression and active vibration suppression functions, effectively reduce vibration.
 3. Easy to maintain and scalable
The detachable structure of cables and batteries allows for the replacement of robots inside the device, and the built-in camera network cable enables various communication extensions.
- **Applications**
It can be used in handling, sorting, assembly, etc.
- **Industries**
Suitable for industries such as 3C electronics, lithium batteries, automotive electronics, and photovoltaics.



SPECIFICATIONS

Model		ESR10-800Z42
Reach		800 mm
Max. payload on wrist	Rated	5 kg
	Maximum	10 kg
Robot weight		25 kg
Maximum speed	J1+J2	9500 mm/sec
	J3	1100 mm/sec
	J4	2000°/sec
Motion range	J1	±132°
	J2	±150°
	J3	420 mm
	J4	±360°
Repeatability	J1+J2	±0.025 mm
	J3	±0.015 mm
	J4	±0.015°
Standard cycle time		0.475 s
J4 allowable moment of inertia	Rated	0.02 kg·m ²
	Maximum	0.3 kg·m ²
Electric lines		D-Sub 15-Pin
Pneumatic lines		φ4 mmx1, φ6 mmx2
J3 downward force		200 N
Installation		Floor
Installation enviroment	Ambient temperature	5~40°C
	Ambient humidity	RH ≤80% (No dew nor frost allowed)

OPERATING SPACE

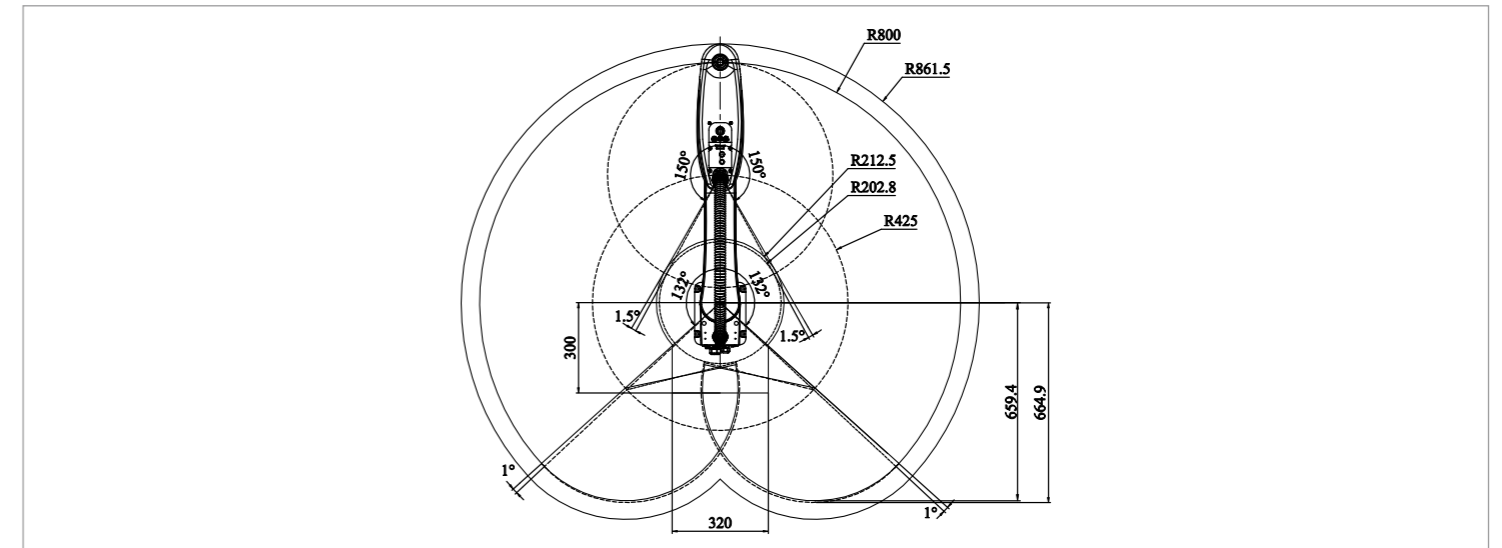

BASE MOUNTING SIZE

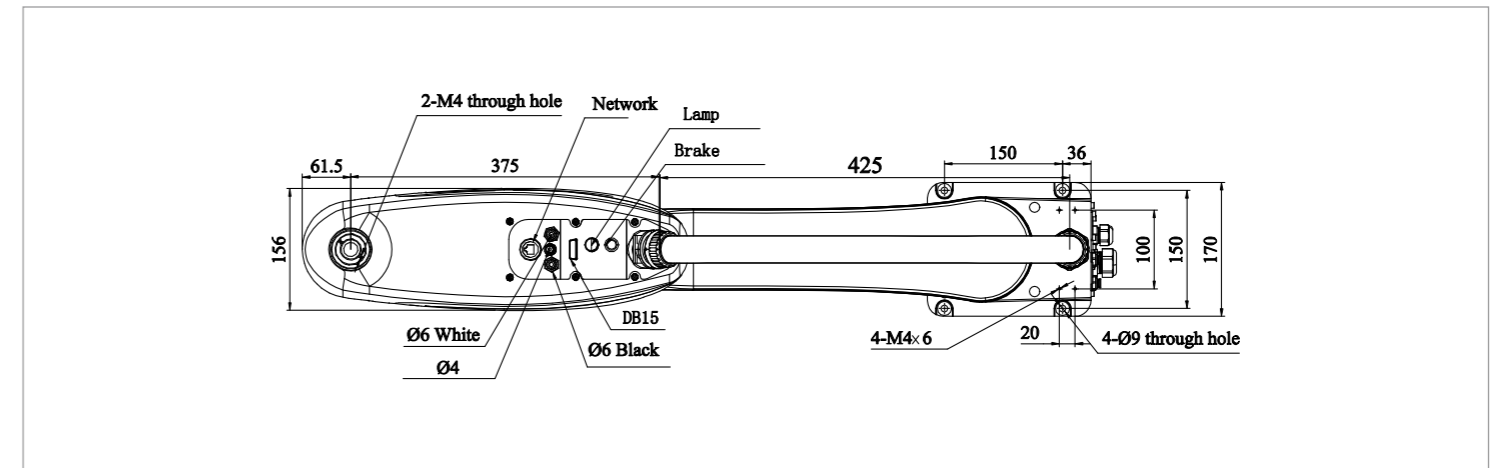

END FLANGE MOUNTING SIZE

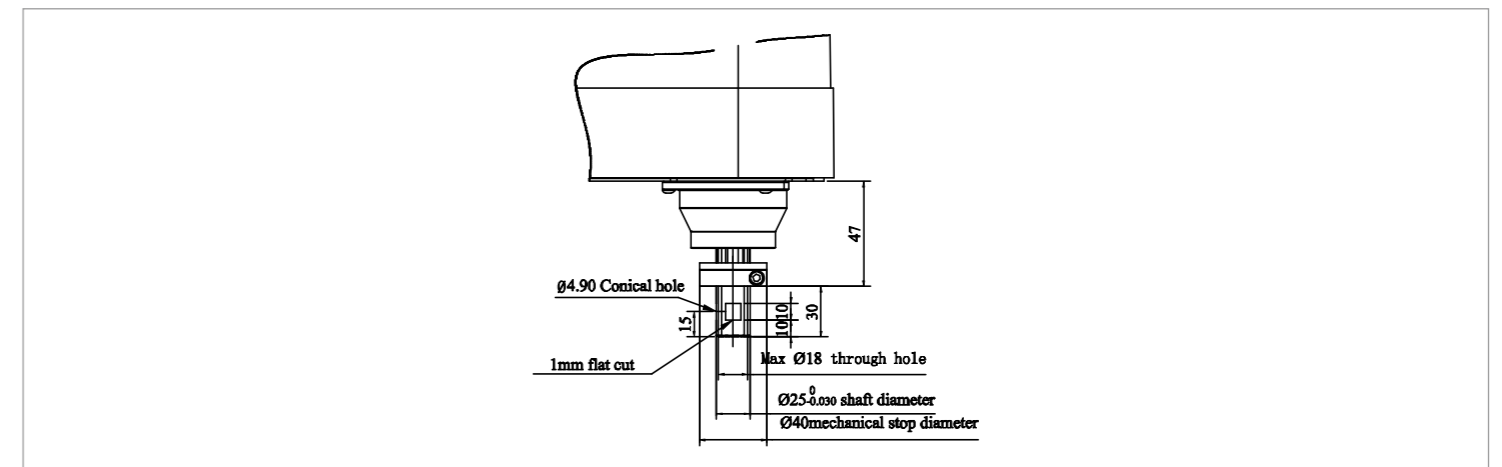

Information Release Time 2024/01

PHONE: (00 86) 400-052-8877
 ADDRESS: No.96 East Wanchun Road, China(Anhui) Pilot
 Free Trade Zone Wuhu Area, Wuhu, Anhui Province, China
 WWW.EFORT.COM.CN

EFORT INTELLIGENT EQUIPMENT CO.,LTD.