

EFORT

ESR10-600Z20

ESR10-600Z20,
Maxium payload 10 kg with maxium reach 600 mm.

- **Highlights**
 1. High rhythm and high precision
The fastest standard cycle time can reach 0.36 s, and the robot positioning accuracy can reach 0.02 mm.
 2. High rigidity and low vibration
Robot body mode and rigidity enhancement, combined with vibration suppression and active vibration suppression functions, effectively reduce vibration.
 3. Easy to maintain and scalable
The detachable structure of cables and batteries allows for the replacement of robots inside the device, and the built-in camera network cable enables various communication extensions.
- **Applications**
It can be used in handling, sorting, assembly, etc.
- **Industries**
Suitable for industries such as 3C electronics, lithium batteries, automotive electronics, and photovoltaics.



SPECIFICATIONS

| | | |
|---------------------------------------|---------------------|-----------------------------------|
| Model | | ESR10-600Z20 |
| Reach | | 600 mm |
| Max. payload on wrist | Rated | 5 kg |
| | Maximum | 10 kg |
| Robot weight | | 22 kg |
| Maximum speed | J1+J2 | 9100 mm/sec |
| | J3 | 1500 mm/sec |
| | J4 | 2500°/sec |
| Motion range | J1 | ±132° |
| | J2 | ±150° |
| | J3 | 200 mm |
| | J4 | ±360° |
| Repeatability | J1+J2 | ±0.02 mm |
| | J3 | ±0.01 mm |
| | J4 | ±0.01° |
| Standard cycle time | | 0.36 s |
| J4 allowable moment of inertia | Rated | 0.02 kg·m ² |
| | Maximum | 0.3 kg·m ² |
| Electric lines | | D-Sub 15-Pin |
| Pneumatic lines | | φ4 mmx1, φ6 mmx2 |
| J3 downward force | | 200 N |
| Installation | | Floor |
| Installation enviroment | Ambient temperature | 5~40°C |
| | Ambient humidity | RH≤80% (No dew nor frost allowed) |

OPERATING SPACE

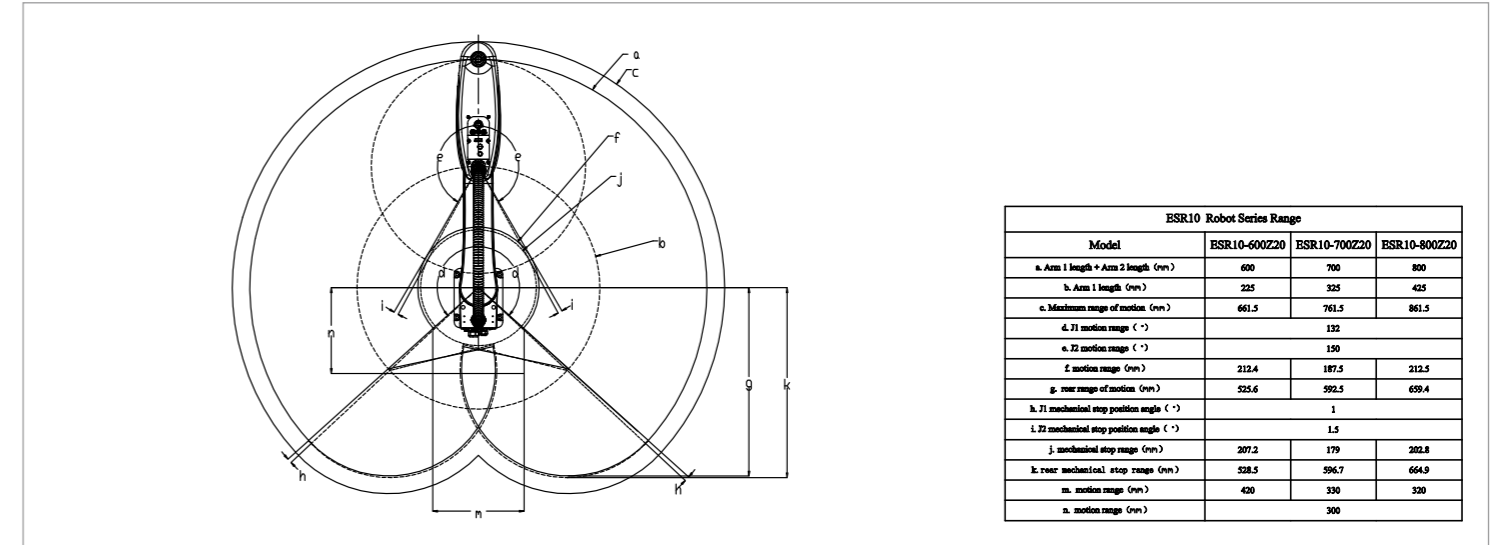

BASE MOUNTING SIZE

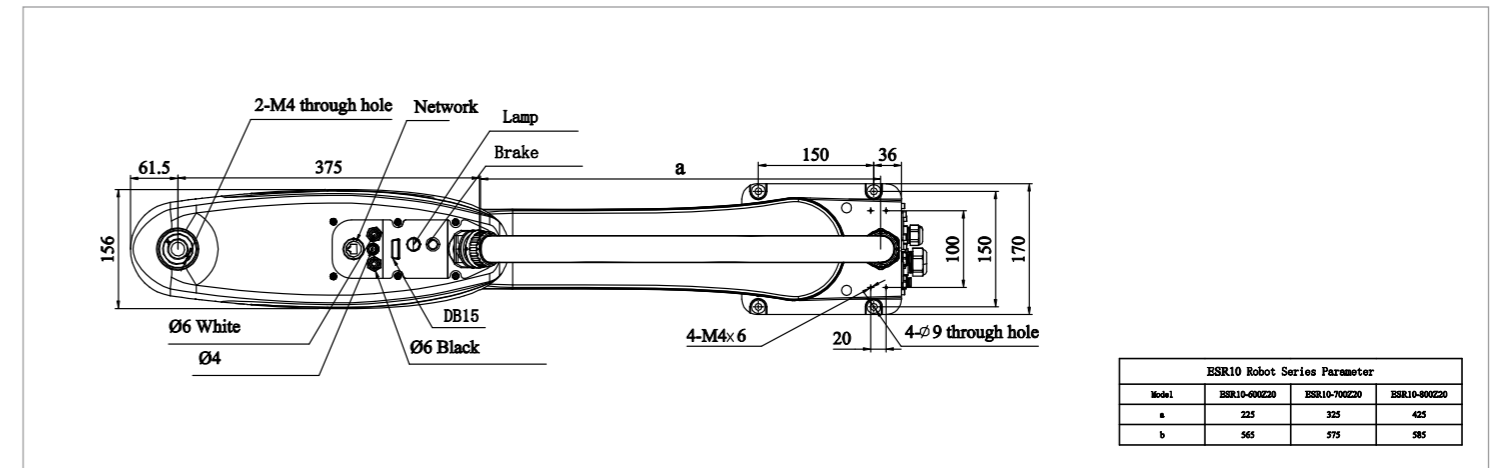

END FLANGE MOUNTING SIZE

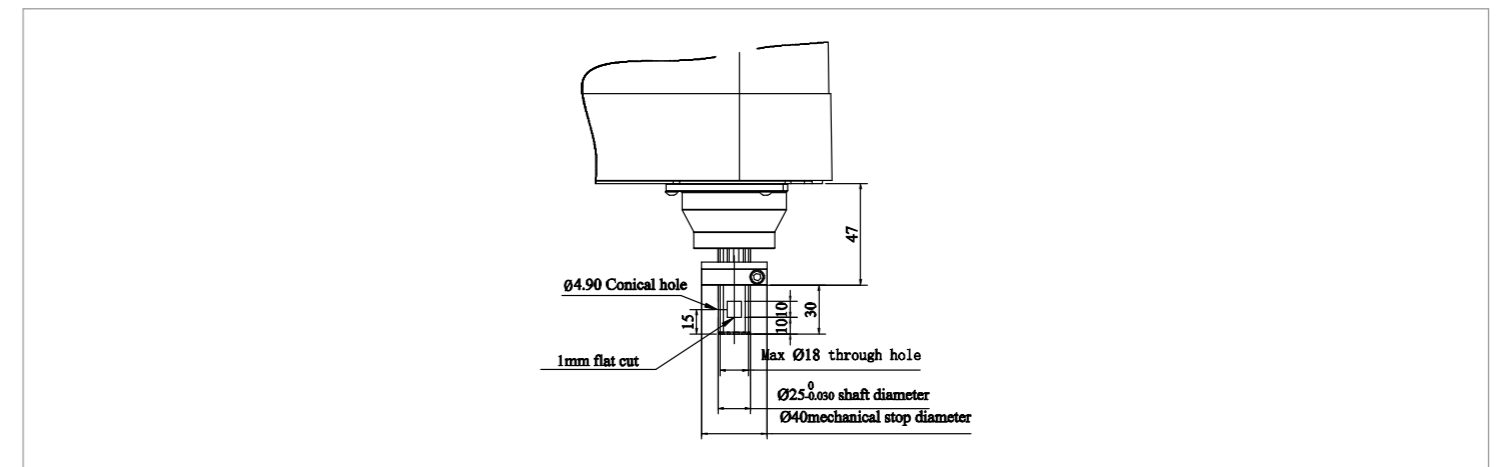

Information Release Time 2024/01

PHONE: (00 86) 400-052-8877
 ADDRESS: No.96 East Wanchun Road, China(Anhui) Pilot
 Free Trade Zone Wuhu Area, Wuhu, Anhui Province, China
 WWW.EFORT.COM.CN

EFORT INTELLIGENT EQUIPMENT CO.,LTD.