

ER35-1900

EFORT

ER35-1900,
Maxium payload 35 kg with maxium reach 1875 mm.

■ **Highlights**

Thanks to the optimization of stiffness and inertia brought by the new mechanical design, with advanced trajectory algorithm. The takt improved by 20%-30%; Compact cabinet design helps customers deploy the production line with more flexibility; IP67 wrist, high protection grade to overcome harsh environment.

■ **Applications**

It can be used in handling operations.

■ **Industries**

Suitable for metal parts, photovoltaic, logistics, food and beverage and other industries.



SPECIFICATIONS

Model	ER35-1900	
Type	Articulated	
Controlled axes	6 Axes	
Max. payload on wrist	35 kg	
Repeatability	±0.05 mm	
Robot weight	275 kg	
Reach	1875 mm	
Robot IP grade	IP54/IP67 (Wrist)	
Cabinet IP grade	IP20/ IP54 (Optional)	
Drive mode	AC servo drive	
Installation	Floor, Upside-down, Wall	
Installation enviroment	Ambient temperature	0~45 °C
	Ambient humidity	RH≤80% (No dew nor frost allowed)
	Vibration acceleration	4.9 m/s ² (<0.5 G)

Allowable load moment at wrist	J4	110 N·m
	J5	110 N·m
	J6	60 N·m
Allowable load inertia at wrist	J4	4 kg·m ²
	J5	4 kg·m ²
	J6	2 kg·m ²
Maximum speed	J1	190°/sec
	J2	190°/sec
	J3	200°/sec
	J4	350°/sec
	J5	350°/sec
	J6	400°/sec
Motion range	J1	±173°
	J2	+105°/-141°
	J3	+200°/-78°
	J4	±190°
	J5	±130°
	J6	±360°

OPERATING SPACE

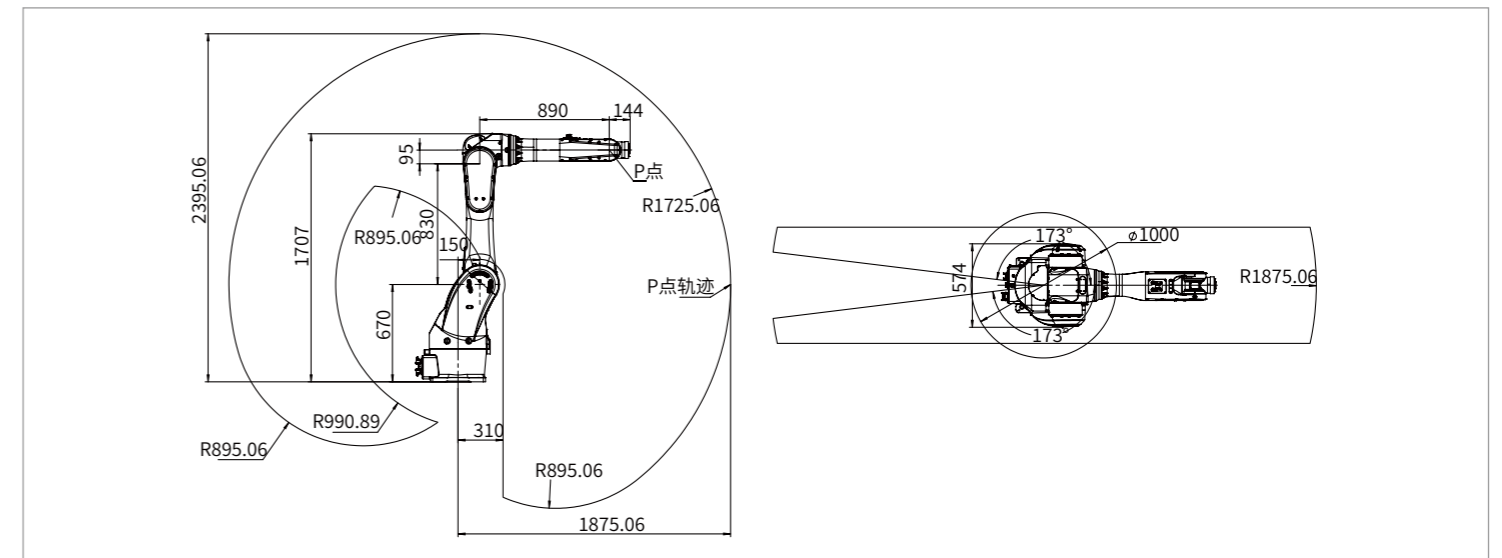

BASE MOUNTING SIZE

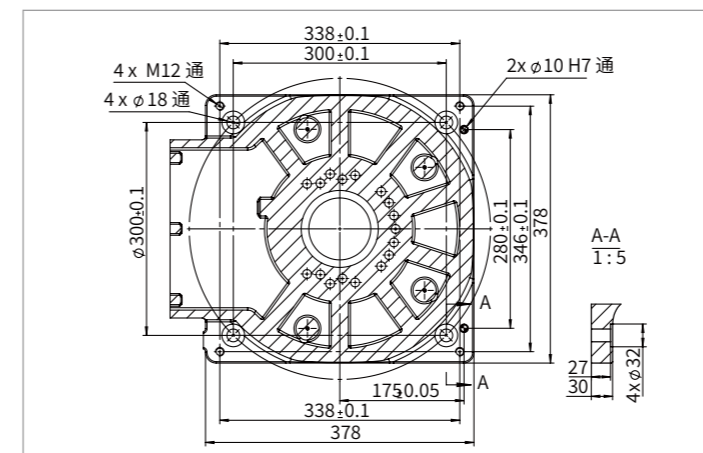

END FLANGE MOUNTING SIZE

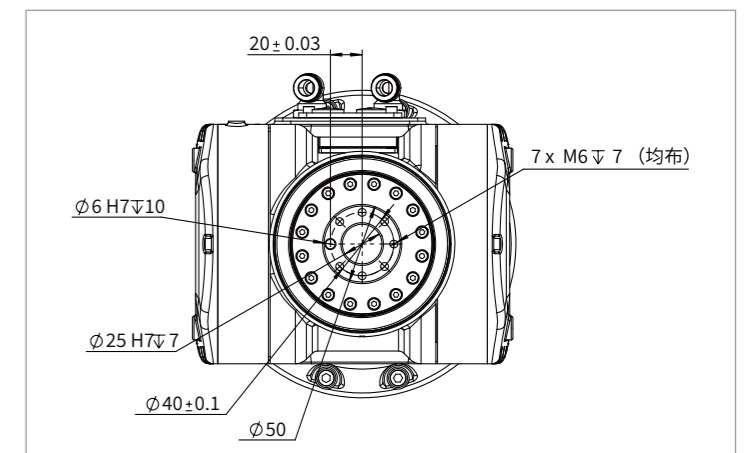

EFORT INTELLIGENT EQUIPMENT CO.,LTD.

PHONE: (00 86) 400-052-8877

ADDRESS: No.96 East Wanchun Road, China(Anhui) Pilot

Free Trade Zone Wuhu Area, Wuhu, Anhui Province, China

WWW.EFORT.COM.CN