

ER25-2300

EFORT

ER25-2300,
Maxium payload 25 kg with maxium reach 2295 mm.

Highlights

Thanks to the optimization of stiffness and inertia brought by the new mechanical design, with advanced trajectory algorithm. The takt improved by 20%-30%; Compact cabinet design helps customers deploy the production line with more flexibility; IP67 wrist, high protection grade, to overcome harsh environment.

Applications

It can be used in handling operations.

Industries

Suitable for metal parts, photovoltaic, logistics, food and beverage and other industries

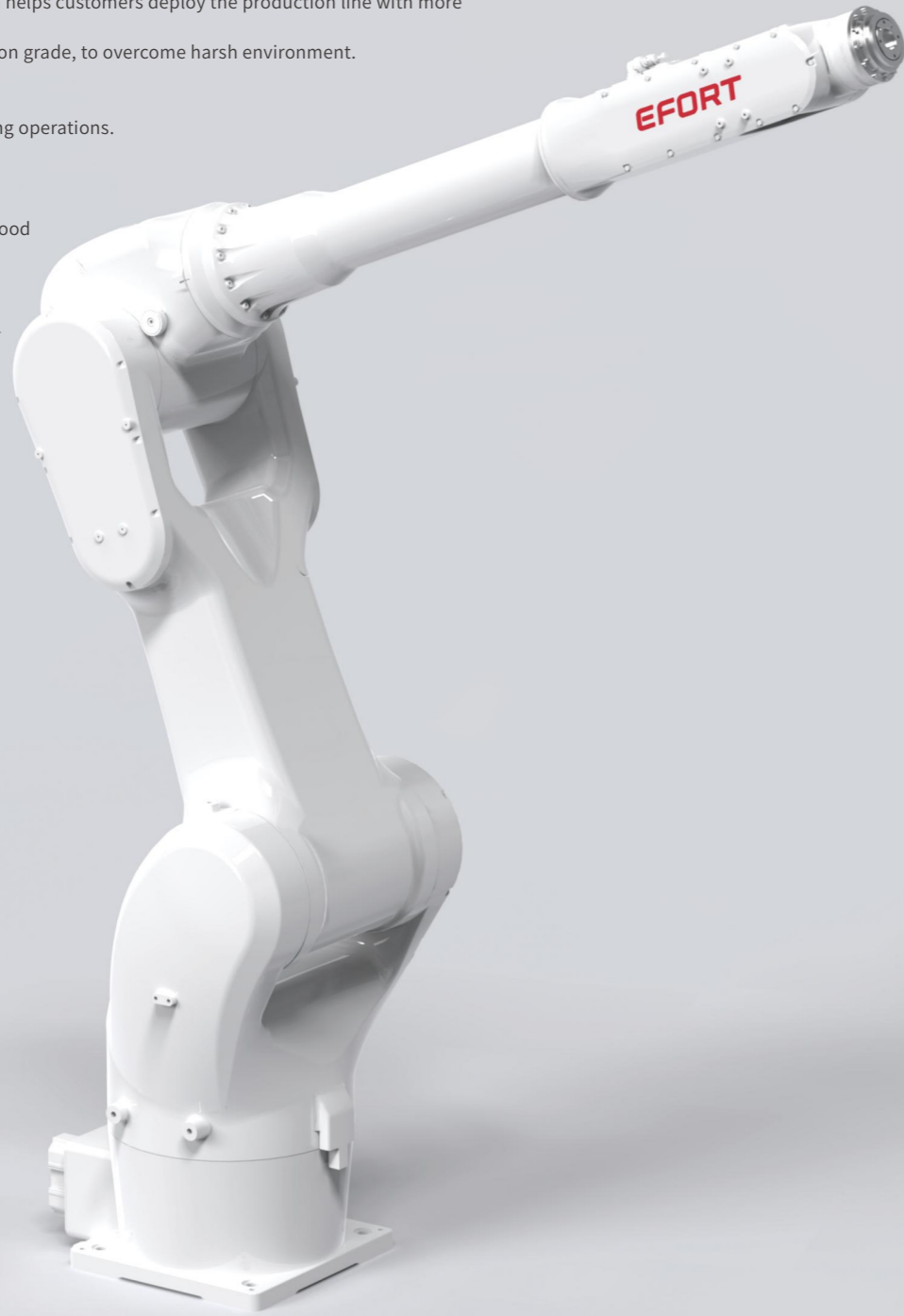

SPECIFICATIONS

Model	ER25-2300	
Type	Articulated	
Controlled axes	6 Axes	
Max. payload on wrist	25 kg	
Repeatability	±0.05 mm	
Robot weight	315 kg	
Reach	2295 mm	
Robot IP grade	IP54/IP67 (Wrist)	
Cabinet IP grade	IP20/IP54 (optional)	
Drive mode	AC servo drive	
Installation	Floor, Upside-down, Wall	
Installation enviroment	Ambient temperature	0~45 °C
	Ambient humidity	RH≤80% (No dew nor frost allowed)
	Vibration acceleration	4.9 m/s ² (<0.5 G)

Allowable load moment at wrist	J4	50 N·m
	J5	50 N·m
	J6	30 N·m
Allowable load inertia at wrist	J4	2.2 kg·m ²
	J5	2.2 kg·m ²
	J6	1.5 kg·m ²
Maximum speed	J1	190°/sec
	J2	190°/sec
	J3	200°/sec
	J4	350°/sec
	J5	360°/sec
	J6	410°/sec
Motion range	J1	±173°
	J2	+105°-141°
	J3	+200°-78°
	J4	±190°
	J5	±130°
	J6	±360°

OPERATING SPACE

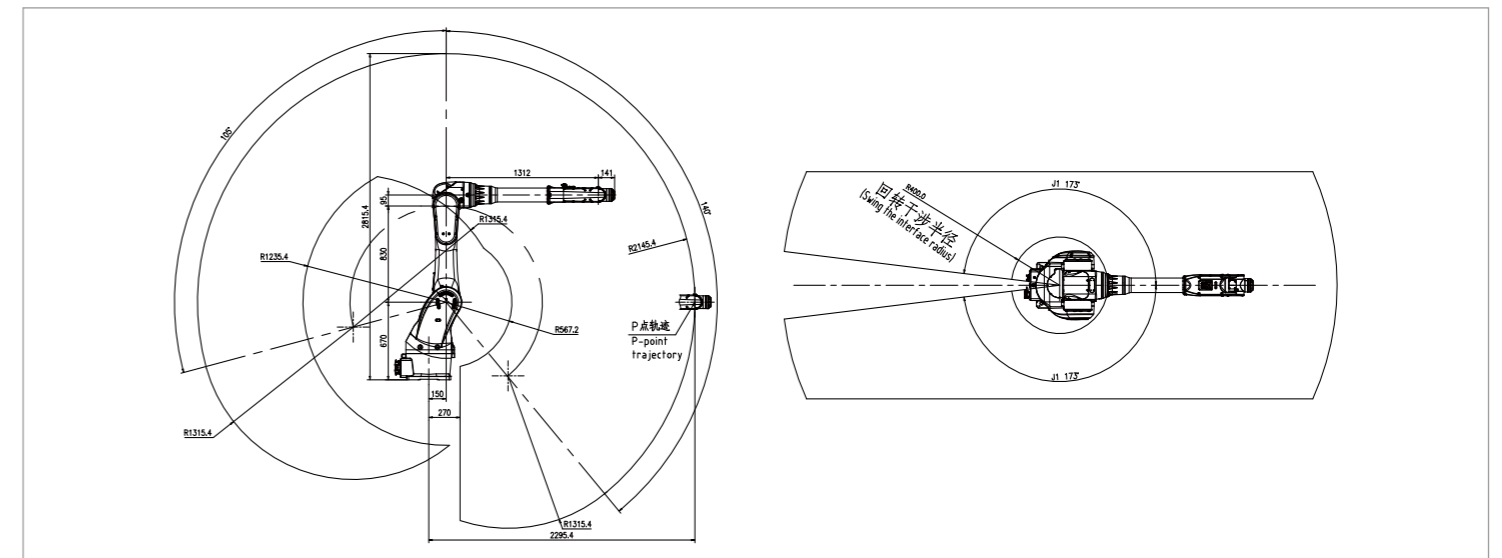

BASE MOUNTING SIZE

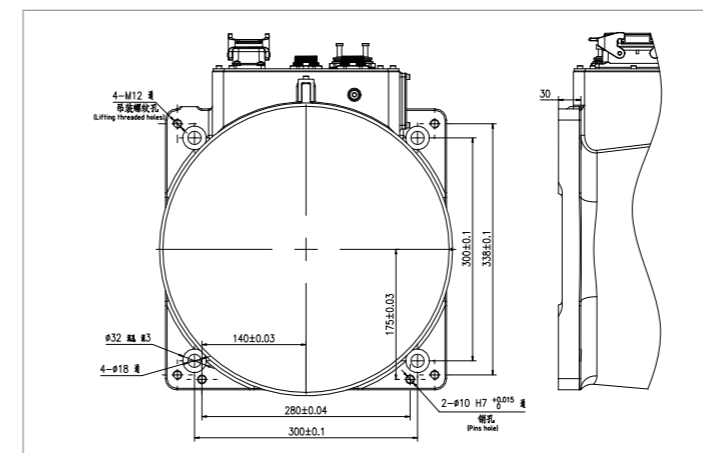

END FLANGE MOUNTING SIZE

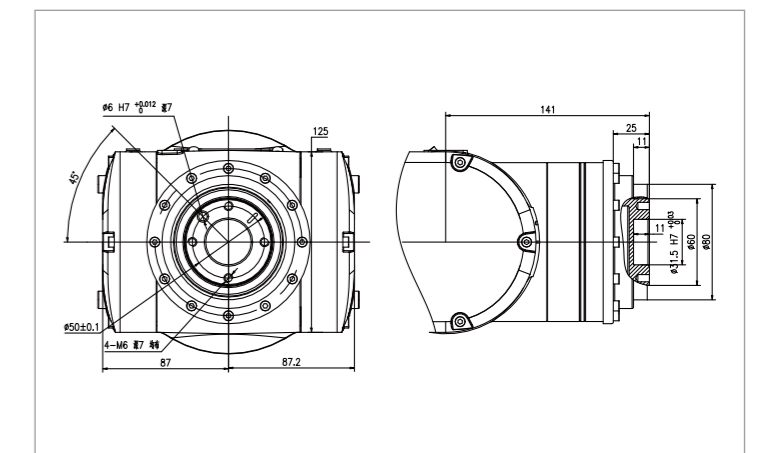

EFORT INTELLIGENT EQUIPMENT CO.,LTD.

PHONE: (00 86) 400-052-8877

ADDRESS: No.96 East Wanchun Road, China(Anhui) Pilot

Free Trade Zone Wuhu Area, Wuhu, Anhui Province, China

WWW.EFORT.COM.CN