

# ER10-900

**EFORT**

**ER10-900,**  
Maxium payload 10 kg with maxium reach 910 mm.

■ **Highlights**

High protection level IP65 of the robor body help customers easy to face dusty, oil misty, high humidity and other harsh environment;  
Thanks to the high stiffness transmission design and advanced trajectory algorithm, the improved robot accuracy performance helps customers to face variety of application scenarios.

■ **Applications**

It can be used for handling operations(machine tending), sorting, assembling, grinding, polishing, Arc welding, etc.

■ **Industries**

Suitable for 3C, food and beverage, metal parts, education, plastic, pharmaceutical and other industries.



**SPECIFICATIONS**

<b>Model</b>	ER10-900	
<b>Type</b>	Articulated	
<b>Controlled axes</b>	6 Axes	
<b>Max. payload on wrist</b>	10 kg	
<b>Repeatability</b>	±0.02 mm	
<b>Robot weight</b>	43 kg	
<b>Reach</b>	910 mm	
<b>Robot IP grade</b>	IP65/IP67 (Wrist)	
<b>Cabinet IP grade</b>	IP20/IP54 (Optional)	
<b>Drive mode</b>	AC servo drive	
<b>Installation</b>	Floor, Upside-down, Wall	
<b>Installation enviroment</b>	<b>Ambient temperature</b>	0~45 °C
	<b>Ambient humidity</b>	RH≤80% (No dew nor frost allowed)
	<b>Vibration acceleration</b>	4.9 m/s <sup>2</sup> (<0.5 G)

<b>Allowable load moment at wrist</b>	<b>J4</b>	20 N·m
	<b>J5</b>	20 N·m
	<b>J6</b>	10 N·m
<b>Allowable load inertia at wrist</b>	<b>J4</b>	0.60 kg·m <sup>2</sup>
	<b>J5</b>	0.60 kg·m <sup>2</sup>
	<b>J6</b>	0.20 kg·m <sup>2</sup>
<b>Maximum speed</b>	<b>J1</b>	300°/sec
	<b>J2</b>	255°/sec
	<b>J3</b>	330°/sec
	<b>J4</b>	450°/sec
	<b>J5</b>	420°/sec
	<b>J6</b>	600°/sec
<b>Motion range</b>	<b>J1</b>	±170°
	<b>J2</b>	+100°-135°
	<b>J3</b>	+200°-75°
	<b>J4</b>	±190°
	<b>J5</b>	±130°
	<b>J6</b>	±360°

**OPERATING SPACE**

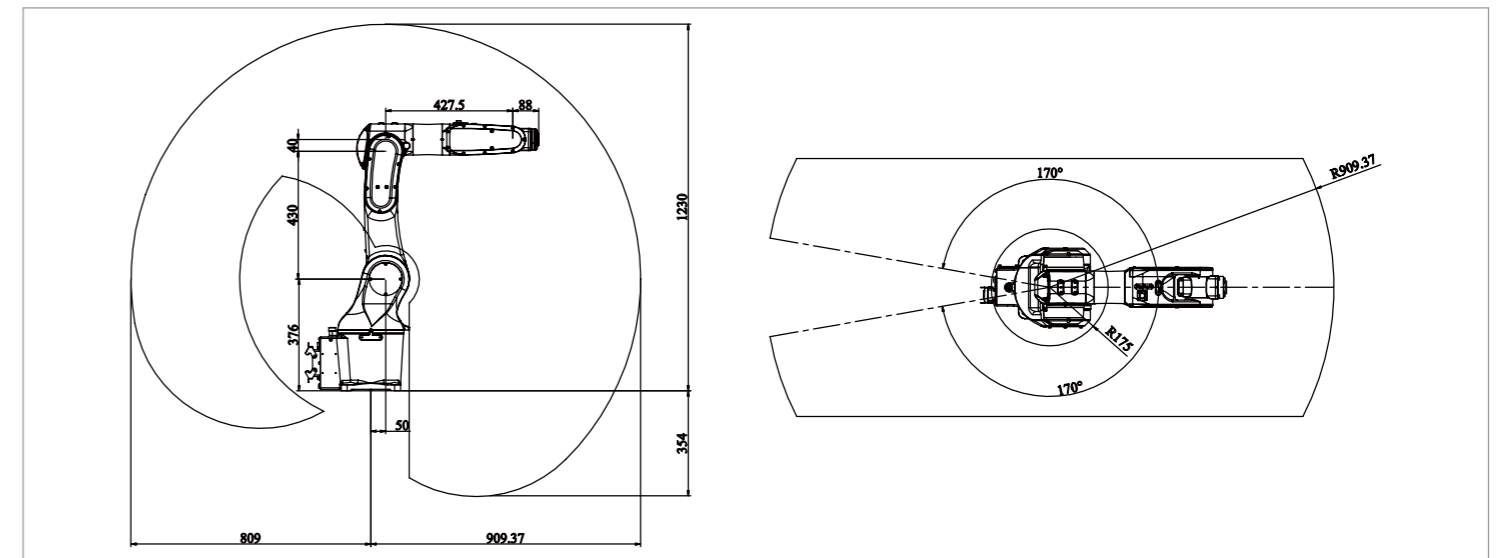

**BASE MOUNTING SIZE**

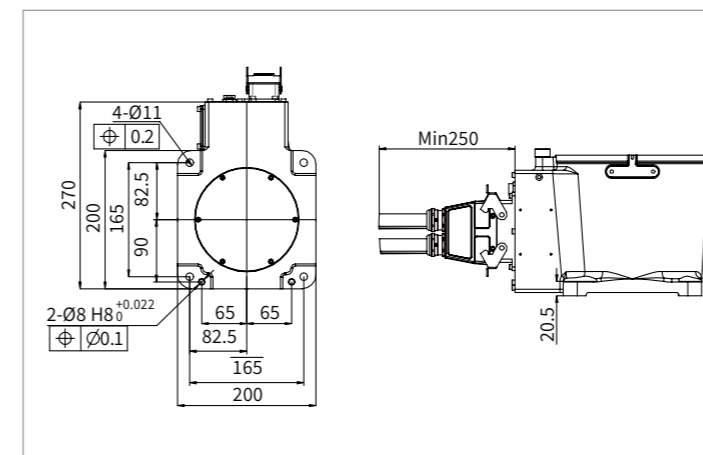

**END FLANGE MOUNTING SIZE**

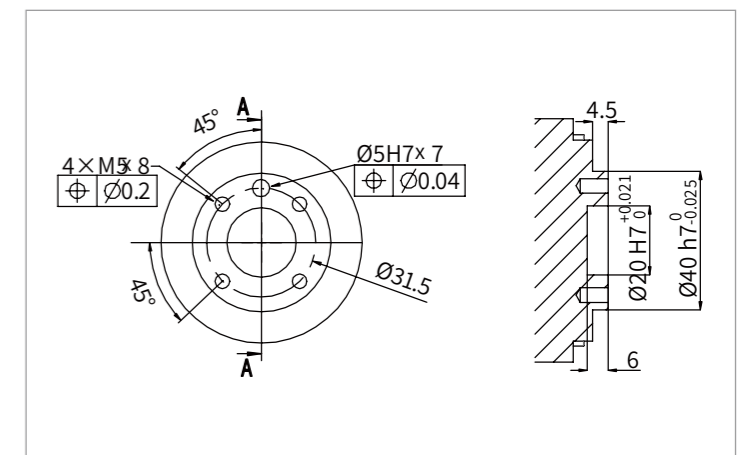

**EFORT INTELLIGENT EQUIPMENT CO.,LTD.**

PHONE: (00 86) 400-052-8877

ADDRESS: No.96 East Wanchun Road, China(Anhui) Pilot

Free Trade Zone Wuhu Area, Wuhu, Anhui Province, China

WWW.EFORT.COM.CN